



# IS 15-25-35-50 IDRA

## insaccatrici verticali

### vertical hydraulic sausage stuffers



Industria 4.0

- Semplici e funzionali, le insaccatrici idrauliche verticali contano su di un potente impianto idraulico che lavora a 120 Bar di pressione.
- Costruite interamente in acciaio inox, totalmente smontabili per la pulizia senza l'uso di attrezzi, vantano caratteristiche proprie di modelli di classe superiore:
  - coperchio e tampone totalmente in acciaio inox;
  - guarnizioni al silicone che agiscono all'interno del cilindro per una maggiore tenuta e durata della guarnizione stessa;
  - protezione ermetica cilindro oleodinamico;
  - stelo pistone in acciaio inox;
  - cilindro in acciaio inox, lucidato e ribordato, senza verso obbligato;
  - potente e silenzioso motore ventilato a 2.800 giri ad azione immediata;
  - ritorno pistone automatico con spegnimento motore;
  - comandi inox IP 67;
  - regolatore flusso olio di alta precisione;
  - ruote gommata di serie;
  - serbatoio olio con indicatore di livello.

#### Opzionale:

- SRCS Scheda di controllo remoto
- *Simple and functional, the hydraulic vertical sausage fillers feature a powerful hydraulic system that operates at a pressure of 120 bars.*
- *Manufactured entirely from stainless steel, the machine can be completely disassembled for easy cleaning without requiring tools. It features characteristics typical of higher category models:*
  - *fully stainless steel cover and piston;*
  - *silicone gaskets that act inside the cylinder for better seal and longer life of the gasket;*
  - *hermetic protection of the hydraulic cylinder;*
  - *stainless steel piston rod;*
  - *polished and rounded stainless steel cylinder, without obligatory direction;*
  - *powerful and silent ventilated motor operating at 2.800 rpm with immediate action;*
  - *automatic piston return when motor stops;*
  - *S/steel IP 67 protected controls;*
  - *high-precision oil flow controller;*
  - *standard rubber wheels;*
  - *oil tank with level gauge.*

#### Optional:

- SRCS wifi control board



IS 25 IDRA



IS 15 IDRA



IS 35 IDRA



IS 50 IDRA



Guarnizione ermetica su cilindro oleodinamico  
Hermetic hydraulic piston gasket

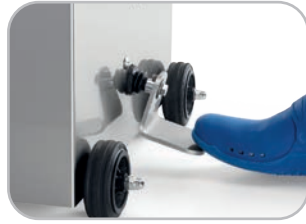

Azionamento spinta pistone  
Piston pushing up



Ritorno pistone automatico  
Automatic piston return



Comandi  
Controls

**Optionals**



Ghiera inox  
Bush in stainless steel



Imbuti inox (ø 16-20-28-38)  
Funnels in stainless steel (ø 16-20-28-38)



Applicazione passa patate  
Potato masher application



Estrema facilità di pulizia  
Easy to clean

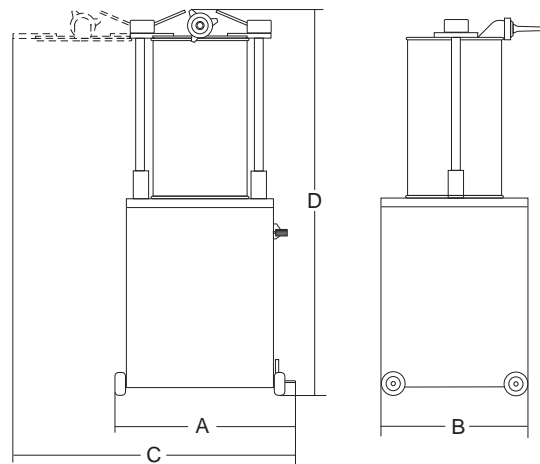

	watt/HP	lt	mm	ø mm	mm	mm	mm	ø mm	mm	mm	mm	mm	kg	mm	kg	
<b>IS 15 Idra</b>	560/0.75	15	495	200	430	2'11"	35°	45°	10-18-25	490	370	700	1200	53	720x570x1380	63
<b>IS 25 Idra</b>	560/0.75	25	460	260	380	2'02"	40°	60°	10-18-25	565	450	950	1160	91	720x570x1380	103
<b>IS 35 Idra</b>	560/0.75	35	460	320	380	2'02"	45°	65°	10-18-25	640	480	1000	1160	101	760x640x1430	113
<b>IS 50 Idra</b>	560/0.75	55	520	380	440	6'	55°	75°	10-18-25	730	550	1130	1250	145	760x640x1430	160